

T4NS/T4NS-SK 安全门开关 Safety-door Switch

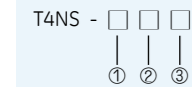

型号说明 Model Designations



项目 Item	代号 Code	说明 Description
① 导管 / 连接器尺寸 Conduit / connector size	1	Pg13.5 (1 导管) Pg13.5 (1 conduits type)
	2	G1/2 (1 导管) G1/2 (1 conduits type)
	4	M20 (1 导管) M20 (1 conduits type)
② 内置开关 Built-in switch	A	1NC/1NO (慢动型) 1NC/1NO (slow-action type)
	B	2NC (慢动型) 2NC (slow-action type)
③ 头部安装方向 Head Mounting Direction	F	四个安装方向可选 (交货时为前侧安装) / 塑料 Four mounting directions possible (Front-side mounting at shipping)/plastic
	D	四个安装方向可选 (交货时为前侧安装) / 金属 Four mounting directions possible (Front-side mounting at shipping)/metal

导管连接器尺寸标配 M20 × 1.5
M20x1.5 cable gland that can be equipped



特性 Characteristics

额定电流 Rating	3A 240VAC
操作速度 Operating speed	0.1m ~0.5m/s
动作频率 Operating frequency	30 次 / 分以下 30 operations/minute
接点电阻 Contact resistance	25mΩ 以下 25mΩ max. (initial).
绝缘电阻 Insulation resistance	100mΩ 以上 (在 500VDC 以下) 100mΩ min. (at 500VDC)
绝缘电压 Rated insulation voltage(Ui)	400V
电介强度 Dielectric strength	AC2500V/Ump 4KV
振动 Vibration	10 至 55HZ, 1.5mm 双振幅
冲击 Shock	机械耐久: 1000m/s ² 以上 (约 100G 以上) 误动作耐久: 300m/s ² 以上 (约 30G 以上) Electrical: Approx. 1000m/s ² (Approx. 100G ⁺ S) Electrical: Approx. 300m/s ² (Approx. 30G ⁺ S)
使用温度 Ambient temperature	-10°C ~+70°C (没有结冰 With no icing)
使用湿度 Ambient Humidity	< 95% RH
使用寿命 Life	电气: 30 万次以上 Electrical: 300,000 operations/min.
重量 Weight	约 96g(T4N-4AF-K1) About 96g (T4N-4AF-K1) 约 104g(配连接器) About 104g (With gland)
防水等级 Degree of protection	IP66 初期值

额定值 Ratings

额定电压 Rated voltage	非电感性负载 Noninductive Load (A)			电感性负载 Inductive Load (A)		
	电阻性负载 Resistance Load	灯泡负载 Lamp Load		电感性负载 Inductive Load	马达负载 Motor Load	
	NC	NO	NO	NC	NO	NO
125 VAC	5 (0.1)	1.5	0.7	3	2.5	1.3
250 VAC	3	1	0.5	2	1.5	0.8
8 VDC	5 (0.1)	2		5	4	3
14 VDC	5 (0.1)	2		4	4	3
30 VDC	4 (0.1)	2		3	3	3
125 VDC	0.4	0.05		0.4	0.4	0.05
250 VDC	0.2	0.03		0.2	0.2	0.03
浪涌电流 Surge current	NC			20A 以下 (under)		
	NO			10A 以下 (under)		

动作特性 Operating Characteristics

操作插入力量 Key plug in force	最大 Max.	14.7N(1,500gf)
操作抽动力量 Key pull out force	最大 Max.	29.42N(3,000gf)
动作距离 Pretravel		6 ± 3mm
总行程 Total travel		(28mm)
强制脱离力 Force required to have positive	最小 Min.	58.84N(6,000gf)
强制脱离距离 Positive opening travel	最小 Min.	10mm

T4NS-4AF
T4NS-4BF

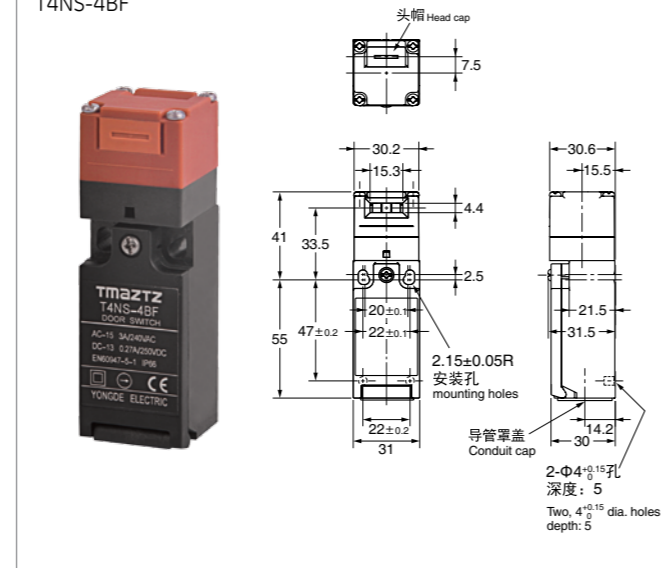

T4NS/T4NS-SK 安全门开关 Safety-door Switch



动作特性 Operating Characteristics

型号 Model	接点 Contact	接点形式 Contact form	动作模式 Operating pattern	备注 Remarks
T4NS-□ A □	1NC/NO		 11-12 33-34 行程 Stroke 操作钥匙插入完成位置 Key insertion completion position 拔出完成位置 Extraction completion position	仅 NC 接点 (11-12) 拥有经认证的强制断开机制。⊕ Only NC contacts 11-12 have a certified direct opening mechanism. 端子 (11-12) 和 (33-34) 能用作异名极。 The terminals 11-12 and 33-34 can be used as unlike poles.
T4NS-□ B □	2NC		 11-12 31-32 行程 Stroke 操作钥匙插入完成位置 Key insertion completion position 拔出完成位置 Extraction completion position	仅 NC 接点 (11-12) 和 (31-32) 拥有经认证的强制断开机制。⊕ NC contacts 11-12 and 31-32 have a certified direct opening mechanism. 端子 (11-12) 和 (31-32) 能用作异名极。 The terminals 11-12 and 31-32 can be used as unlike poles.

外观和尺寸 Appearance and Dimension

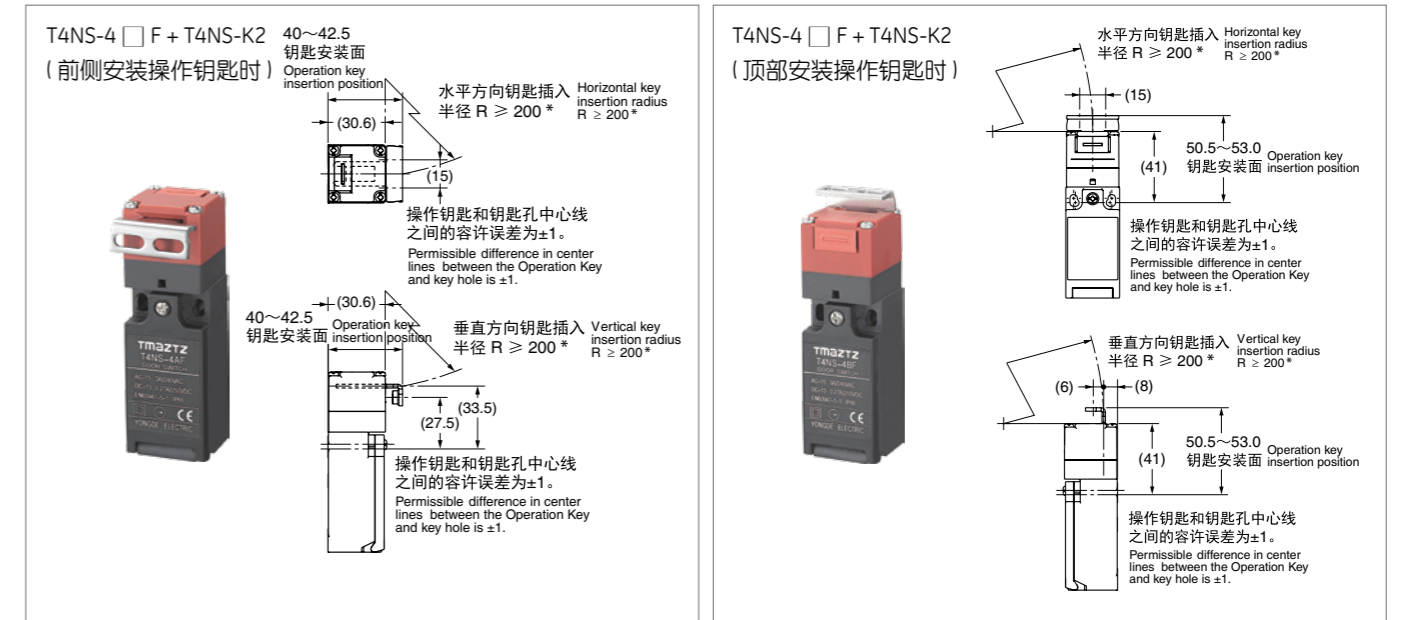
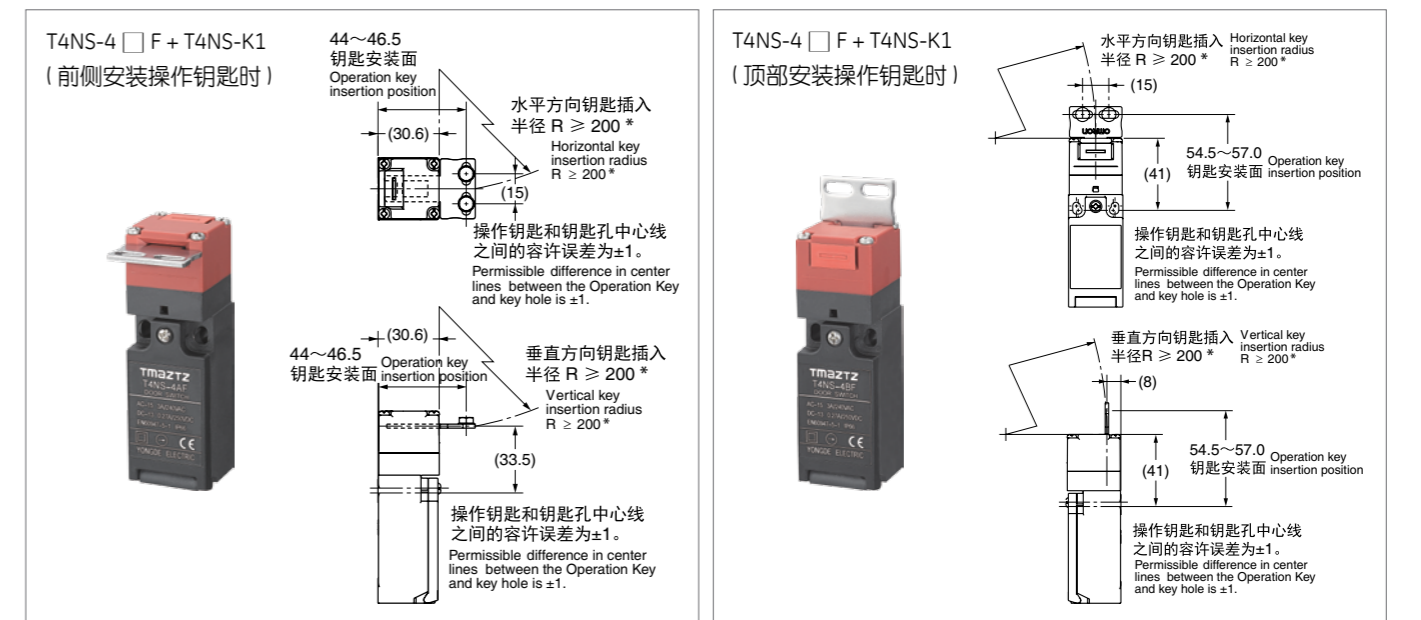

外观和尺寸 Appearance and Dimension

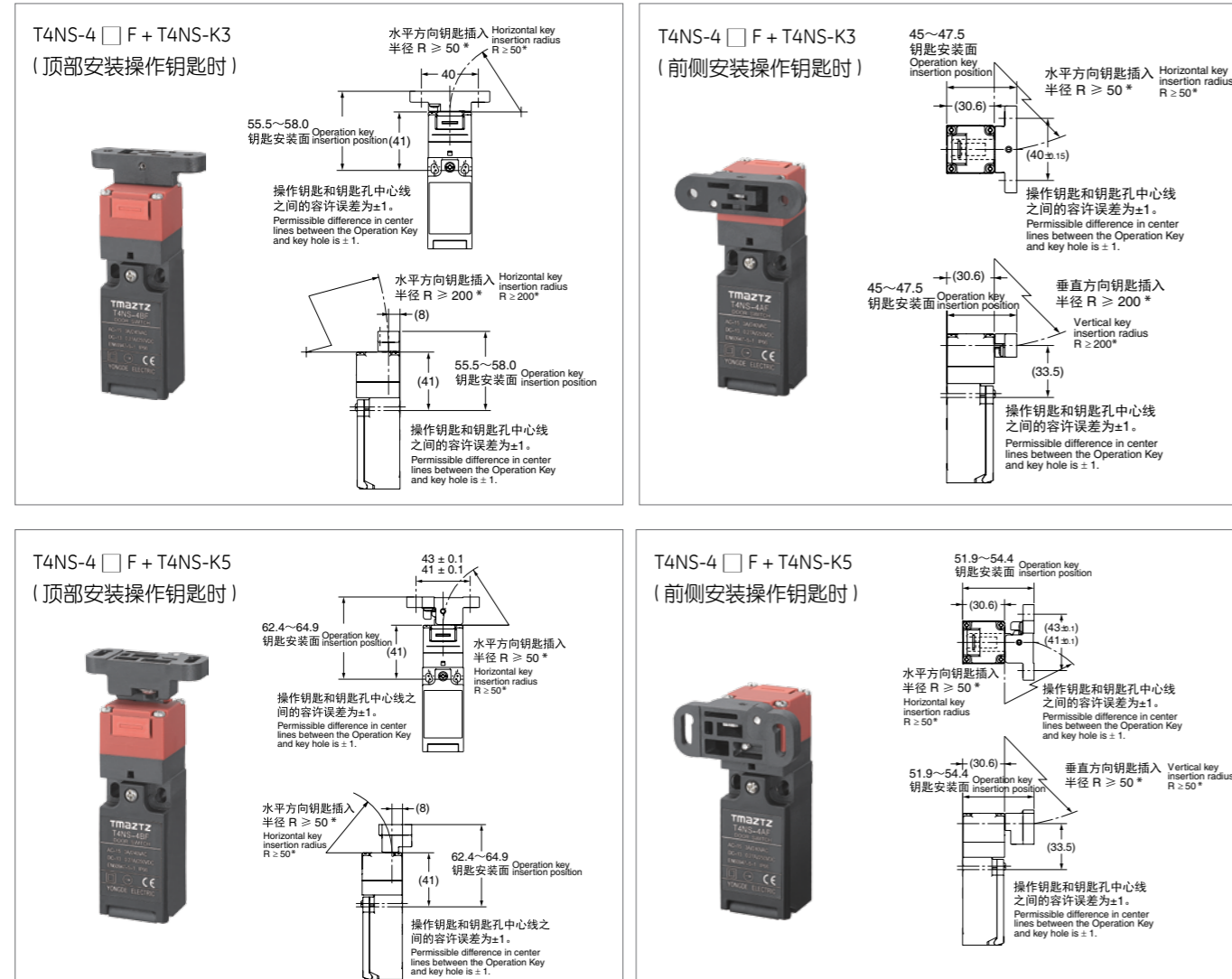

操作钥匙 Operating the key

